

**REQUEST FOR TENDER  
Eden Community Park Pavilion  
RFT 26-01**



**ISSUE DATE:** Monday April 27, 2026

**CLOSING DATE:** Wednesday May 13, 2026

**CLOSING TIME:** 11:00 A.M., local time

**LOCATION:** Municipality of Bayham  
P.O. Box 160  
56169 Heritage Line  
Straffordville, ON,  
N0J 1Y0

Attention: Steve Adams  
Manager of Public Works

**LATE SUBMISSIONS WILL NOT BE ACCEPTED**

**NOTE: It is the vendor's sole responsibility to ensure their submissions are received in a sealed enveloped clearly marked with RFT 26-01 Eden Community Park Pavilion by the time and date specified within the document.**

**The Lowest or Any Bid Will Not Necessarily Be Accepted**

Municipality of Bayham  
P.O. Box 160  
56169 Heritage Line  
Straffordville, ON  
N0J 1Y0

**Company Name &  
Address:** \_\_\_\_\_

**Please return this cover sheet with your submission**

## GENERAL INDEX

SECTION A	TERMS AND CONDITIONS	pages	2-10
SECTION B	INFORMATION FOR BIDDERS	pages	11-12
SECTION C	FORM OF TENDER	pages	13-20
SECTION D	GENERAL AND CONTRACT ITEM SPECIAL PROVISIONS	pages	21

## SECTION A – TERMS AND CONDITIONS

### Section 1 – General Conditions

#### 1.1 Form of Tender

All Tenders must be upon the forms provided, submitted in sealed packages, clearly marked with the tender number and project description. The package shall include one (1) original. Please see “Completion of Tender” for a listing of documents to include for this submission.

#### 1.2 Definitions

<b>Corporation:</b>	Refers to “The Corporation of the Municipality of Bayham”
<b>Owner:</b>	Refers to “The Corporation of the Municipality of Bayham”
<b>Respondent:</b>	Refers to “any eligible entity providing a Tender”
<b>Successful Respondent:</b>	Refers, in the event of an award, “to the selected Respondent”, and may be pluralized if awarded to multiple parties. “Contractor” will be deemed to have a corresponding meaning with respect to various forms and obligations to be confirmed during the RFT process and any subsequent construction associated with the RFT award.
<b>RFT</b>	Refers to “Request for Tender”

#### 1.3 Tender Closing

Tender submissions must be received by the Municipality of Bayham, 56169 Heritage Line Straffordville, ON N0J 1Y0. Attention: Steve Adams, Manager of Public Works no later than:

**11:00 A.M. local time, Wednesday May 13, 2026**

**Please note that delivery of bids by mail or all couriers on the tender closing day, in the morning, is not guaranteed.**

**It is recommended to hand-deliver bids intended to be received on the closing day.**

The Corporation is not responsible for Submissions which are not properly marked and/or delivered to any other location, than that specified.

#### 1.4 Tender Opening

Respondents are advised there will be a public opening for this RFT. Submissions received, by the date and time of closing, will be opened administratively by respective members of the Corporation at closing time.

#### 1.5 Electronic Submissions

Electronically transmitted submissions (e-mail, fax, etc.) will not be accepted for this Tender.

#### 1.6 Inquiries / Clarification

Inquiries must be received no later than three (3) business days prior to the closing date of the RFT; otherwise, a response may not be provided.

## **1.7 Late Submissions**

Tenders received after the official closing time will not be considered during the selection process and will be returned unopened to the respective Respondent(s).

## **1.8 Completion of the Tender**

All entries shall be clear and legible, and made in a non-erasable medium, and signed in ink. All items shall be submitted according to any instruction in the Request for Tender Documents.

Alterations may be made, providing they are legible and initialled by the Respondent's signing officer. Tenders which are incomplete, conditional, illegible or obscure, or that contain additions not called for, reservations, erasures, alterations incorrectly submitted, or irregularities of any kind may be rejected.

## **1.9 Tender Withdrawal**

Any Tender may be withdrawn prior to the scheduled time for Tender Closing, or authorized postponement thereof.

## **1.10 Respondent Expense**

Any expenses incurred by the Respondent in the preparation of the Tender submission are entirely the responsibility of the Respondent and will not be charged to the Corporation.

## **1.11 Examination of Request for Tender Documents**

Each Respondent must satisfy himself/herself by a personal study of the RFT documents respecting the conditions existing or likely to exist in connection with the proposed work. There will be no consideration of any claim, after Submission of Tenders, that there is a misunderstanding with respect to the conditions imposed by this RFT.

Prices must include all incidental costs and the Respondent must be satisfied as to the full requirements of the RFT. No claims for extra work will be entertained and any additional works must be authorized in writing prior to commencement. Should the Respondent require more information or clarification on any point, it must be obtained prior to the submission of the RFT.

## **1.12 Acceptance or Rejection of Tenders**

**1.12.1** The Corporation reserves the right to reject any or all Tenders, and to waive formalities as the interests of the Corporation may require without stating reasons therefore.

The Corporation also reserves the right to enter into negotiations with the lowest compliant bidder if the price bid is over the budgeted amount for the project. Should the Corporation be unable to reach an agreement with the lowest compliant bidder, the Corporation reserves the right to enter into negotiations with the next lowest compliant bidder, or to cancel the call – whichever is deemed to be in the best interest of the Corporation.

**1.12.2** Notwithstanding and without restricting the generality of the statement immediately above, the Corporation shall not be required to award or accept a Tender, or recall the Tenders at a later date:

- a) When only one Tender has been received as a result of the Tender call.
- b) Where the lowest responsive and responsible Respondent substantially exceeds the estimated cost of the goods or service.

- c) When all Tenders received fail to comply with the Specifications or Tender Terms and Conditions.
- d) Where a change in the scope of work or specifications is required.

**1.12.3** The Corporation shall not be responsible for any liabilities, costs, expenses, loss or damage incurred, sustained or suffered by any Respondent by reason of the acceptance or the non-acceptance by the Corporation of any Tender or by reason of any delay in the acceptance of a Tender, except as provided in the Tender document.

**1.12.4** Each Tender shall be open for acceptance by the Corporation for a period of thirty (30) calendar days following the date of closing.

**1.12.5** Where the Tender documents do **not** state a definite delivery/work schedule and a submitted Tender is based on an unreasonable delivery/work schedule, the Tender may be rejected.

### **1.13 Inquiries, Discrepancies and Interpretations**

Should a Respondent find omissions from or discrepancies in any of the RFT documents, or should the Respondent be in doubt as to the meaning of any part of such documents, the Respondent shall notify the designated contact person and office without delay. If the designated contact person considers that a correction, explanation or interpretation is necessary or desirable, an addendum will be issued to all who have received RFT documents.

No oral explanation or interpretation will modify any of the requirements or provisions of the Tender documents.

### **1.14 Errors and/or Omissions**

The Corporation shall not be held liable for any errors and/or omissions in any part of this RFT. While the Corporation has used considerable efforts to ensure an accurate representation of information in this RFT, the information contained in the RFT is supplied solely as a guideline for Respondents. The information is not guaranteed or warranted to be accurate by the Corporation, nor is it necessarily comprehensive or exhaustive. Nothing in the RFT is intended to relieve the Respondents from forming their own opinions and conclusions with respect to the matters addressed in the RFT.

### **1.15 Addenda**

If required by the Corporation, addenda will be distributed to all Proponents registered as a document taker for this Tender. Addenda will be distributed via email using the latest contact information as provided by the Proponent. It is the Proponent's responsibility to notify the Corporation of any changes to their email or mailing address. It is the Proponent's ultimate responsibility to ensure all addenda have been received.

### **1.16 Tender Award Procedures**

Unless stated otherwise, the following procedures will apply:

**1.16.1** The Corporation will notify the Successful Respondent(s) of the award within thirty (30) calendar days of the Tender Closing.

**1.16.2** Notice of Acceptance of Tender will be by telephone and by written notice.

**1.16.3** Immediately after acceptance of the Tender by the Corporation, The Successful Respondent(s) shall provide the Corporation with the *Certificate of Liability Insurance*

and any other required documents within fourteen (14) calendar days of the date of Notification of Acceptance & Award.

**1.16.4** Following receipt of the required documents, the Successful Respondent(s) will receive written authority, in the form of a Professional Services Agreement and/or official Purchase Order, to proceed with the Work.

**1.17 Ability and Experience of Respondent(s)**

It is not the purpose of the Corporation of the Municipality of Bayham to award this contract to any Respondent(s) who does not furnish satisfactory evidence of possessing the ability and experience in this class of work and sufficient capital to ensure acceptable performance and completion of the Tender. The Corporation of the Municipality of Bayham reserves the right to be our own reference and may disqualify a Respondent on this basis.

**1.18 Responsibility for Damages**

The successful Respondent(s) shall indemnify and hold harmless the Corporation, its officers and employees from and against any and all liabilities, claims, demands, loss, cost, damages, actions, suits or other proceedings by whomsoever made, directly or indirectly arising out of the project attributable to bodily injury, sickness, disease or death or to damage to or destruction of tangible property caused by any acts or omissions of the Respondent(s), its officers, agents, servants, employees, customers, invitees or licensees, or occurring in or on the premises or any part thereof and, as a result of activities under this Tender.

**1.19 Regulation Compliance and Legislation**

The successful Respondent(s) shall ensure all services and products provided in respect to this Tender are in accordance with, and under authorization of all applicable authorities, Municipal, Provincial and/or Federal legislation and Standards.

**1.20 Sub-Consultants**

No sub consultants or collateral agreements shall be permitted with respect to the work of this assignment, except with the Corporation's express written consent and, in advance of commencement of sub consultant activities.

**Failure to obtain this consent may result in cancellation of the contract with the Successful Respondent(s).**

**1.21 Indemnity**

The Successful Respondent shall indemnify and save harmless the Owner and its officers from all claims, demands, losses, costs, damages, actions, suits or proceedings by whomsoever made, occasioned by or attributable to the activities or omissions of the Successful Respondent or those for whom the Successful Respondent is responsible in performing the Contract.

**1.22 Protection of Work and Property**

The successful respondent shall provide continuous and adequate protection of all work from damage and shall protect the Owner's property from injury or damage arising from or in connection with this work. The successful Respondent(s) shall make good any such damage or injury.

**1.23 Character and Employment of Workers**

The successful Respondent(s) shall employ only orderly, competent, and skilful employees to ensure that the services are carried out in a respectable manner.

In the event that any person employed by the Successful Respondent(s) in connection with the service arising out of this Tender gives, in the opinion of the Corporation, just cause for complaint, the successful Respondent(s) upon notification by the Corporation in writing, shall not permit such person to continue in any future service arising out of this Tender.

**1.24 Freedom of Information**

All correspondence, documentation and information provided shall become the property of the Municipality. Any personal information required on the documentation presented is received under the authority of the Municipal Freedom of Information and Protection of Privacy Act, 1989, RSO, 1990. This information will be an integral component of the quote submission.

All written Tenders received by the Municipality become a public record.

Once a Tender is accepted by the Municipality of Bayham, and a contract is signed, all information contained in them is available to the public, including personal information. Questions about collection of personal information and the Municipal Freedom of Information and Protection of Privacy Act, 1989, R.S.O. 1990, Chapter M.56, as amended, should be directed to:

**Clerk, Municipality of Bayham  
56169 Heritage Line, Straffordville, Ontario  
N0J 1Y0**

**Telephone (519) 866-5521**

## **Section 2 – Specific Conditions**

### **2.1 Notification of Award**

The Corporation will notify only the respondent(s) presenting the awarded Tender(s) in writing.

### **2.2 Budget Approval**

The Municipality of Bayham reserves the right to remove and/or delay portions of the contract depending upon approvals and/or budgetary restraints, or for any other reason that may arise.

### **2.3 Patent, Copyright, or other Proprietary Rights**

In accordance with Municipal Freedom of Information and Protection of Privacy Act, Respondents are reminded to clearly identify in their Tender material, any specific scientific, technical, commercial, proprietary, intellectual or similar confidential information, the disclosure of which could cause them injury or damage.

Respondents are encouraged to place all such details and information within a separate section of their submission. Complete Tender details are **not** to be identified as “Confidential”.

### **2.4 Harmonized Sales Tax (HST)**

All prices within this document shall be quoted exclusive of HST.

### **2.5 Terms of Payment**

The normal terms of payment for the Corporation will be net thirty (30) calendar days. Invoices shall be forwarded to:

Municipality of Bayham  
56169 Heritage Line  
PO Box 160  
Straffordville, ON  
N0J 1Y0

### **2.6 Unbalanced or Incorrect Tenders**

Where the amount of an item does not agree with the extension of the estimate quantity and the tendered unit price, the unit price shall govern and both the item amount and the total tender price shall be corrected accordingly. If both the unit price and the total price for an item are left blank, then both shall be considered a zero. If the unit price is left blank, but a total price is shown for the item, then the unit price shall be determined by dividing the total price by the estimated quantity.

### **2.7 Performance**

Any undue delays in the execution of the work and/or costs incurred by the Corporation due to inefficiencies in performance on behalf of the successful Respondent(s) shall be deemed to be the responsibility of that Respondent(s) and as such, any and all costs, as deemed appropriate and reasonable compensation for the Corporation, will be assessed to the successful Respondent(s).

## **2.8 Taking the Work Out of the Successful Respondent's Hands**

Where the Successful Respondent becomes bankrupt or insolvent, delays commencing or diligently executing the Work, abandons the Work or has otherwise failed to perform any of the provisions of the Contract, the Owner may, without previous notice and without process or suit at law, take the work out of the hands of the Successful Respondent and have it completed by whatever means are considered necessary. In addition to any other remedy available in law or equity, the Owner may use all monies due on the Contract to correct or complete the work.

## **2.9 Assignment of Contract**

The Successful Respondent shall not assign transfer, convey, sublet or otherwise dispose of this contract or his/her right, title or interest therein, or his power to execute such contract, to any other person, company or corporation, without the previous consent, in writing, of the Corporation's officials, which consent shall not be unreasonably withheld.

## **2.10 Contact(s)**

All inquiries relative to this RFT shall be directed to:

**Main Contact:**

Steve Adams  
Manager of Public Works  
[sadams@bayham.on.ca](mailto:sadams@bayham.on.ca)

Questions of clarification will be answered individually, but response(s) to any question that modifies the scope of the RFT will be circulated in writing as an RFT Addendum to all Respondents who have received the RFT document from the Corporation.

Inquiries must be received no later than three (3) business days prior to the closing date of the RFT; otherwise, a response may not be provided.

## **2.11 Tender Evaluation**

All submissions must be in compliance with the requirements of the RFT process in order to be considered.

## **2.12 Insurance Requirements**

### **a) Commercial General Liability**

The Successful Respondent shall, at his/her expense, obtain and keep in force during the term of this Agreement, Commercial General Liability Insurance satisfactory to the Municipality, including the following and underwritten by an insurer licensed to conduct business in the Province of Ontario:

- i) A limit of liability of not less than \$2,000,000/occurrence.
- ii) The Municipality shall be named as an additional insured;
- iii) The policy shall contain a provision for cross liability in respect of the named insured;
- iv) Non-owned automobile coverage with a limit of at least \$2,000,000 including contractual non-owned coverage;
- v) Products and completed operation coverage (Broad Form) with an aggregate limit not less than \$2,000,000.

vi) That 30 days prior notice of an alteration, cancellation or material change in policy terms which reduces coverage shall be given in writing to the Municipality;

b) Proof of Insurance

The Successful Respondent shall provide, together with its Executed agreement, a certificate(s) of insurance of certified copy(s) of the above-referred to policies, satisfactory to the Municipality, together with proof of renewal at least ten (10) days prior to expiry. Provided that if a certificate is provided, all requirements as above set forth must be shown on the said certificate and notwithstanding the provision of any certificate, the Municipality may require that the Successful Respondent provides a certified copy of the policy.

**2.13 Workplace Safety & Insurance Board**

The Successful Respondent shall provide the Municipality a valid WSIB Clearance Certificate.

The Successful Respondent, will be expected to comply with the health and safety policies as approved by Council as well as all applicable legislation set out in the current Occupational Health and Safety Act. **Proof of training specific to ladder safety and working at heights certification must be provided with the form of tender.**

All applicable current health and safety legislation and environmental legislation and regulations are considered the minimum requirements that the Successful Respondent must meet. The Successful Respondent must ensure that all of their employees and sub-contractors have safety training and certifications equal to, or exceeding, the requirements set forth in the current Occupational Health and Safety Act and current regulations. Health and Safety issues will always be given immediate attention by the Municipality and its representatives, and the Successful Respondent and its sub-contractors, if applicable.

All employees, contractors/sub-contractors, suppliers and visitors/residents must immediately report unsafe conditions, incidents, and accidents to the Project/Site Supervisor/ Inspector.

The Municipality takes pride in the commitment of our employees and contractors, and will take the necessary steps to ensure Health & Safety on all projects.

**2.14 Laws, Notices, Permits & Fees**

The Successful Respondent shall obtain the necessary permits, licenses and pay the required fees, as they pertain to this assignment, which are in force at the date of the Tender Closing. The building permit is the responsibility of the Owner.

The Successful Respondent shall give the required notices and comply with the laws, ordinances, rules, regulations, codes and orders of the authorities having jurisdiction which are, or become, in force during the period for which services are performed in accordance with the schedule of work.

**2.15 Extra Work**

No work shall be regarded as extra work, unless it is ordered in writing by the Corporation and with the agreed price for the same specified in said order, provided said price is not otherwise determined by the Tender. A statement of the cost of extra work shall be made within thirty (30) calendar days after the completion of the said extra work.

## **2.16 Cancellation**

- a) The Corporation reserves the right to immediately terminate the Contract for sufficient cause, including but not limited to such items as non-performance, late deliveries, inferior quality, pricing problems, etc.
- b) If the Successful Respondent should neglect to execute the work properly, or fail to perform any provision of this Award, the Corporation, after three (3) business days written notice to the Successful Respondent, may, without prejudice to any other remedy in existence, make good such deficiencies and may deduct the cost thereof from any payment then and thereafter due to the Successful Respondent. Continued failure of the Successful Respondent to execute the work properly shall result in a termination of Contract. The Corporation shall provide written notice of termination.
- c) The Corporation may elect to terminate the Contract if the original terms and conditions are significantly changed, giving thirty (30) calendar day's written notice to the Successful Respondent.
- d) Either party may terminate the Contract by giving the other party sixty (60) calendar day's written notice, giving reasons acceptable to the other. A period of less than sixty (60) calendar days to terminate the contract may be negotiable if mutually agreeable among the parties involved in the Contract.
- e) Failure to maintain the required documentation during the term of this contract may result in suspension of the work activities and/or cancellation of the Contract.

## **2.17 Consultants**

Any consultant involved in developing the specifications intended to be used with the Tender process cannot be involved in the creation of the response to those specifications.

## **2.18 Conflict of Interest**

This Tender is made by the Respondent without any connection, knowledge, comparison of figures or arrangement with any other person or persons making a Tender for the same work, and is in all respects fair and without collusion or fraud.

## **2.19 Length of Contract**

Work to be completed by no later than September 30, 2026

## **2.20 Contract Award**

Without limiting all other rights that may be exercised by the Corporation pursuant to this Document, vendors are advised that the Corporation reserves the right to fully evaluate tender submissions, which evaluation may include, without limitation, a review of references, past performance history, completion history (including extended completion dates), litigation history (including construction liens filed by subcontractors for non-payment) and claims history of the vendors, and to reject a tender submission if same is not satisfactory to the Corporation.

## SECTION B - INFORMATION FOR BIDDERS

- 1 **PREPARATION OF SPECIFICATIONS AND SUPERVISION OF WORK**
  - a) The specifications for the Work have been prepared by the Municipality of Bayham Public Works Department, who will monitor work to be done under this Contract. Periodic inspection will be provided on the Contract by Municipality of Bayham staff, who will also administer the contract works.
  - b) Questions with respect to this RFT are to be directed in writing to Steve Adams, Manager of Public Works: [sadams@bayham.on.ca](mailto:sadams@bayham.on.ca)
  - c) Should a Tenderer find discrepancies, omissions, or ambiguities, or not agree that the materials and methods specified or designed, will provide an installation which meets the requirements of the intended Work, he/she shall notify the Municipality prior to the Tender opening date. The Municipality may choose to issue a written addendum. Addenda issued during the tendering period will be allowed for by the Tenderer in submitting his Tender.
- 2 **LOCATION OF WORK**
  - a) Eden Community Park, 56959 Eden Line, Eden – Municipality of Bayham
- 3 **SCOPE OF WORK**
  - a) The work includes all labour and materials required to construct the Pavilion as per the attached plans, specifications, and general notes along with all requirements as set out in the current Ontario Building Code. The Successful Respondent is responsible for site cleanup and final grading including hydroseeding to the satisfaction of the Municipality.
  - b) The front gable shall be reinforced to be able to mount a naming sign to the front.
  - c) Site preparation being staking the area will be the responsibility of the Municipality of Bayham Public works Department.
  - d) Successful Respondent to supply truss package suitable to the Municipality's Chief Building Official. The Municipality requires truss package before building permit application process. The Municipality will lead the building permit application process.
  - e) Successful Respondent to supply and install White Diamond Rib metal ceiling throughout pavilion. Trims, blocking and nailing plates along with attic assess to be supplied by Successful Respondent. Adequate blocking shall be provided at the centre of the pavilion to accommodate a future interior light fixture.
  - f) Successful Respondent to supply and install roof strapping with 2" by 4" Spruce and 1.5-inch 24 gauge **Standing Seam Metal Roof**. Colour to be determined by Municipality before order date.
  - g) Successful Respondent to supply and install 4-inch eavestrough down two sides with 4 down spouts not more than 16 inches from ground height. All trims fascia and soffit to be completed by Successful Respondent. Colour to be determined by

Municipality prior to ordering.

- h)** Successful Respondent to supply and install **Textured Board and Batten Siding System** in 24-gauge steel including all trims. Colour to be determined by Municipality before order date.
- i)** Topsoil and hydroseed to be completed within 1 week of completion of Pavilion.

#### **4 UNBALANCED OR INCORRECT TENDERS**

- a)** The unit price quoted in the Form of Tender shall be reasonable unit price for each item. The Municipality shall be the sole judge of such matters. The Municipality may reject any tender considered by the Municipality to be unbalanced.
- b)** Where the amount of an item does not agree with the extension of the estimate quantity and the tendered unit price, the unit price shall govern and both the item amount and the total tender price shall be corrected accordingly. If both the unit price and the total price for the item are left blank, then both shall be considered a zero. If the unit price is left blank, but a total price is shown for the item, then the unit price shall be determined by dividing the total price by the estimated quantity.
- c)** Notwithstanding the values that may have been read out at the tender opening, the corrected tender values, as determined by the procedures described in b) above shall be used to establish the ranking of the tenders.

#### **5 LIQUIDATED DAMAGES**

- a)** The tenderer's attention is drawn to Form of Tender Liquidated Damages regarding the Liquidated Damages under this Contract.

#### **6 COMPLETION DATE**

All works to be completed by no later than September 30, 2026

- a)** The Successful Respondent will be required to submit a schedule prior to commencing the work which will indicate clearly the proposed commencement date and number of days to complete the work. The Municipality reserves the right to alter such schedule should it be deemed necessary.
- b)** Request for extensions of the time must be addressed to the Municipality in writing, the Municipality at its discretion, will allow for such extensions if warranted. The Municipality will be the sole judge of providing and extension.

## **SECTION C - FORM OF TENDER**

### **Submission of Tender Documents**

Please ensure your Tender submission includes the following documents:

- Cover Sheet
- Form of Tender
- Respondent's Ability and Experience Form
- Schedule of Price Forms
- Bidder Information
- WSIB Clearance Certificate
- Working At Heights and Ladder Training Certificates
- Health & Safety Responsibilities



PLEASE RETURN THIS FORM WITH YOUR SUBMISSION

RESPONDENT INFORMATION FORM

Bidders must complete this form and name one person to be the contact for the RFT response and for any clarifications or amendments that might be necessary.

1.	Full Legal Name of Respondent:	
2.	Any Other Relevant Name Under Which the Respondent Carries on Business:	
3.	Street Address:	
4.	City, Province/State:	
5.	Postal/Zip Code	
6.	Office Toll Free Number (if any):	
7.	Office Phone Number:	
8.	Office Fax Number:	
9.	Company Website (if any):	
10.	WSIB Clearance Number (if applicable):	
11.	HST Account Number:	
12.	RFT Contact Person's Name and Title:	
13.	RFT Contact Person's Office Phone Number:	
14.	RFT Contact Person's Cell Phone Number:	
15.	RFT Contact Person's Fax Number:	
16.	RFT Contact Person's E-mail:	

RESPONDENT'S NAME &  
TITLE

SIGNATURE

DATE

Form of Tender

To: The Mayor and Council of the  
Municipality of Bayham  
P.O. Box 160  
Straffordville, ON  
N0J 1Y0

Attached you will find a certified cheque for the sum of 10% of the Contract Price:

\_\_\_\_\_  
(Name of Company)

in accordance with the General Conditions.

Having examined the Contract Documents for the Eden Community Park Pavilion, dated April 27, 2026, prepared by Municipality of Bayham, and having received the following addenda issued by the Consultant during the tender period,

\_\_\_\_\_  
\_\_\_\_\_  
\_\_\_\_\_

and having examined the site and all conditions affecting the Work, we, the undersigned General Contractor propose to furnish all labour, equipment and materials and complete the Contract as called for by the said Documents in the time specified for the following amount:

(a) Building Work (exclusive of trades below)	\$ _____
(b) Contingency	\$ _____
Sub-Total of Above	\$ _____
13% Harmonized Sales Tax (on sub-total)	\$ _____
<b>TOTAL CONTRACT AMOUNT \$</b>	

\_\_\_\_\_/100 Dollars  
(Total Contract Amount to be Written in Full)

The above Total Contract Amount includes all Harmonized Sales Tax (H.S.T.). It is specifically understood that the Contingency is to be expended only as directed by the consultant, and that any unused portion of this allowance shall revert to the Owner.

Form of Tender (cont'd)

We agree to guarantee all of the Work for a minimum period of one (1) year from the date of acceptance (substantial completion) of same by the Municipality.

We also agree that if our Tender is accepted, we will furnish a 100% Performance Bond and a 50% Labour and Materials Payment Bond, such bonds shall be acceptable in every way to the Owner.

If awarded the Contract, we agree to complete the Work substantially by September 30, 2026, and be finally completed by December 31, 2026.

The following is a list of the sub-trades we propose to use:

<u>TRADE</u>	<u>NAME OF SUBCONTRACTOR OR SUPPLIER</u>
Concrete Contractor	_____
Framing Contractor	_____
Steel roofing	_____

Our Tender includes the following Allowance:

Contingency Allowance	<u>\$ 5,000.00</u>
-----------------------	--------------------

We, the undersigned General Contractor, by this Tender, offer to complete the Contract in accordance with the terms contained herein.

Dated \_\_\_\_\_ this \_\_\_\_\_ day of \_\_\_\_\_, 2026

Witness \_\_\_\_\_

Signature of Authorized  
Person signing for General  
Contractor

\_\_\_\_\_  
Corporate Name of General Contractor

\_\_\_\_\_  
Address of General Contractor

\_\_\_\_\_  
Telephone Number

**BIDDER'S EXPERIENCE**

We declare that we have the following experience in similar work which we have successfully completed.

Year	Description Of Contract	For Whom Work Performed	Value
_____	_____	_____	_____
_____	_____	_____	_____
_____	_____	_____	_____
_____	_____	_____	_____
_____	_____	_____	_____
_____	_____	_____	_____
_____	_____	_____	_____
_____	_____	_____	_____

**PLEASE RETURN THIS FORM WITH YOUR SUBMISSION**

## CONFIRMATION OF FAVOURABLE HEALTH AND SAFETY PRACTICE FORM

The Contractor(s): \_\_\_\_\_

The Municipality of Bayham is committed to:

- i. The prevention of workplace injury and illness to all workers at Municipal locations.
- ii. The belief that contractor safety is compatible with the safety policy of the Municipality and is good business.
- iii. Assuming a leadership role by citing contractors for any violations of the contract.
- iv. To ensure the Municipal workplace is a healthy and safe working environment, contractors, constructors and subcontractors must have knowledge if and operate in compliance with the Occupational Health and Safety Act and other legislation pertaining to employee health and safety.
- v. For long term contracts, or contracts involving pre-selected contractors, the Township reserves the right to cancel (or place on probation) the contract of any contractor who is charged and/or convicted of offences under the Occupational Health and Safety Act while carrying out any part of a project with the Municipality.

Contractor's Statement of Responsibility:

As a contractor retained to perform work for the Municipality of Bayham, I/we accept the following health and safety responsibilities:

- i. I/we will comply with all procedures and requirements of the Occupational Health and Safety Act, Municipal safety policies and procedures, department and site specific policies and procedures and all applicable legislation or regulations.
- ii. I/we will work safely with skill and care so as to prevent accidental injury to ourselves, fellow employees and all other persons on the site of work.
- iii. For contracts or sub-contracts that involve commercial motor vehicles as defined by the Highway Traffic Act, I/we acknowledge possession of a current Carrier CVOR abstract with one of the following safety ratings: Excellent; Satisfactory; Conditional, or Satisfactory-Unaudited.
- iv. I/we will advise the Municipality if the CVOR safety rating of our firm is changed to "Unsatisfactory" at any time during the course of the contract and, upon request, will provide the Municipality with a copy of the most recent Carrier CVOR abstract indicating the sanctions imposed by the Ministry of Transportation.

\_\_\_\_\_  
Contractor

\_\_\_\_\_  
Name of Person Signing for Contractor

\_\_\_\_\_  
Signature of Contractor

\_\_\_\_\_  
Date



## **SECTION D - GENERAL AND CONTRACT ITEM SPECIAL PROVISIONS**

### **SP1 GENERAL**

a) All work is for the supply of all labour, equipment and materials required to complete the works as set out herein.

### **SP2 SAFETY**

a) The Contractor will be responsible to take all necessary steps to protect personnel ( workers, visitors, general public, etc.) and property, from any harm during the course of the Contract. All work procedures and equipment shall be in accordance with the Contractor's and legislated standards.

b) Only competent personnel will be permitted on-site. The inspector will determine who is competent, and will cause to remove from the site any persons not observing or complying with safety requirements. The Contractor shall supply competent personnel to implement their safety program and ensure that the Contractor's standards, and those of the Occupational Health and Safety Act, are being complied with.

c) The Municipality of Bayham will monitor daily to ensure that safety requirements are met. Continued disregard for safety standards can cause the Contract to be cancelled and the Contractor removed from the work site.

d) The Contractor shall report to the jurisdictional authorities, any accident or incident involving Contractor, Municipality or public personnel and/or property, arising from the Contractor's execution of the work.

e) The Contractor shall include all provisions of this Contract and any agreement with subcontractors, and hold all subcontractors equally responsible for safe work performance.

f) If the Contractor is responsible for delay in the progress of the work due to an infraction of legislated or Contractor Health and Safety requirements, the Contractor will, without additional cost to the Municipality, work such overtime not to delay in the final completion of the work or any operations thereof.

### **SP3 INCIDENTAL ITEMS**

a) The following is a partial list of items, the cost of which is to be included in the unit prices of the tender items. No additional payment will be made for the following:

- . Cost of inflated insurance.
- . Cost of permits and fees.

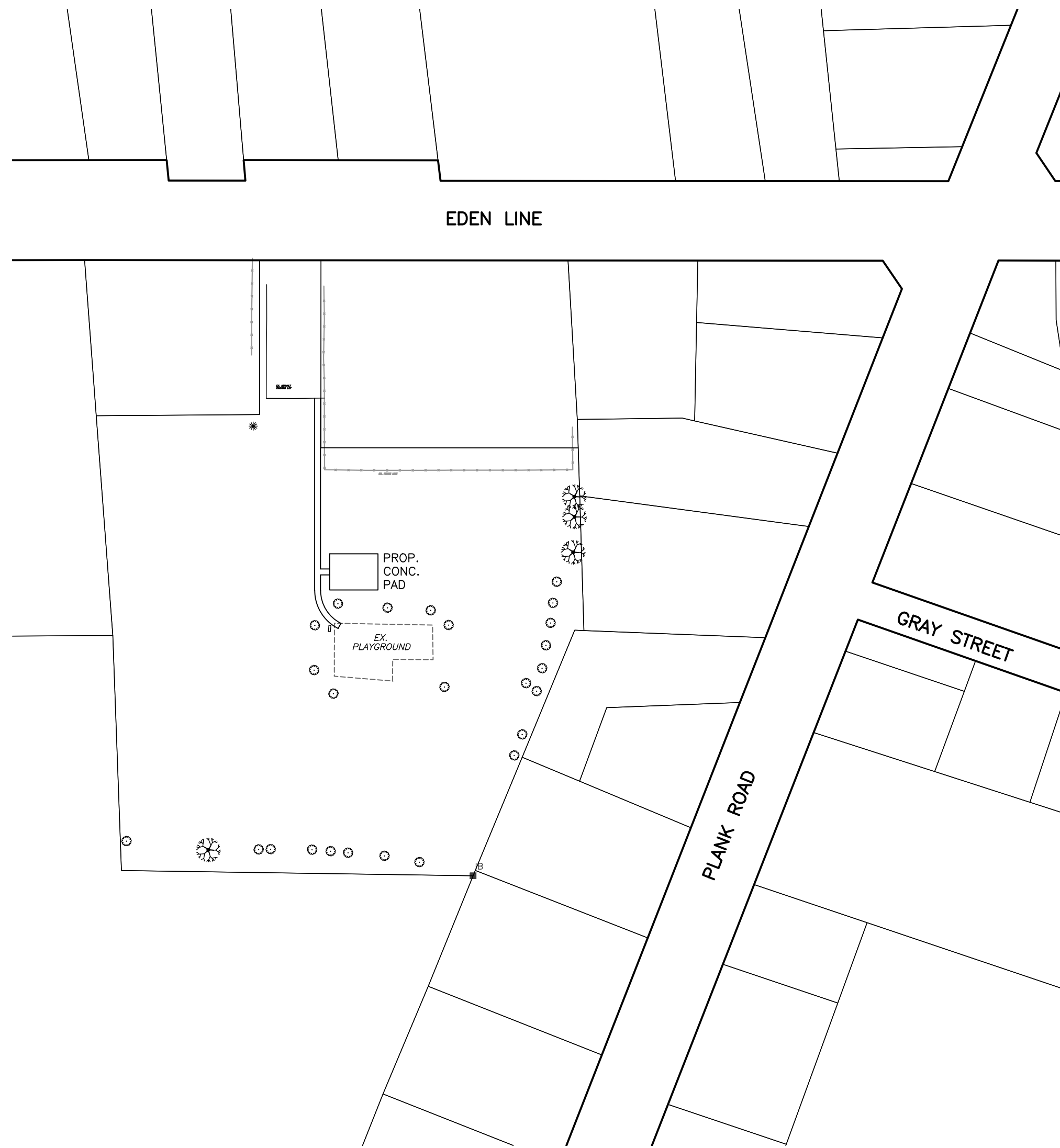

**SITE PLAN**  
SCALE: 1 : 1000

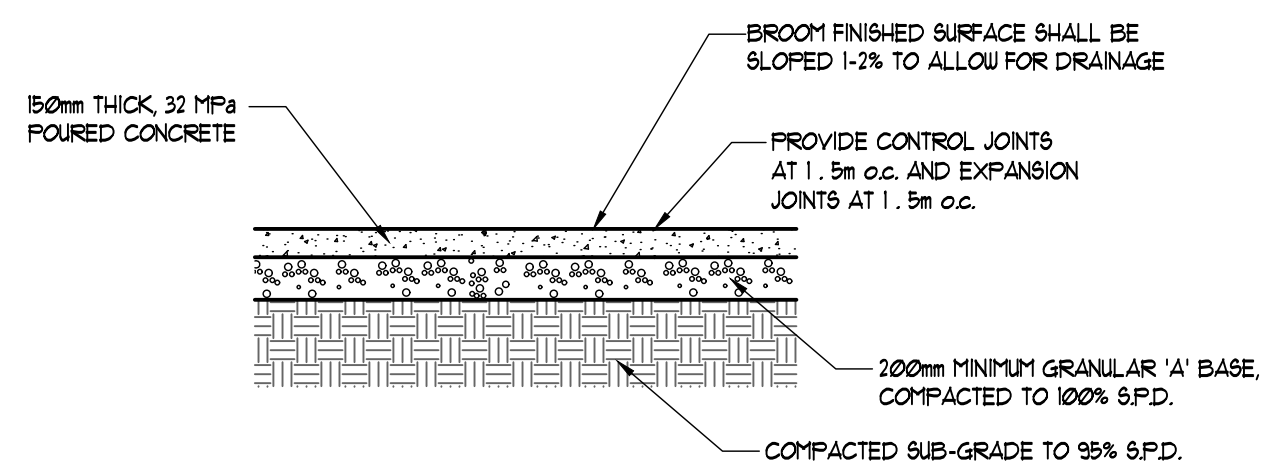
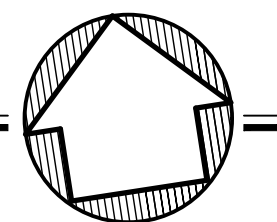

**SIDEWALK DETAIL**  
SCALE: N.T.S.

**GENERAL NOTES**

1. CONTRACTOR SHALL OBTAIN ALL REQUIRED WORK PERMITS AT HIS OWN COST.
2. DISTANCES AND ELEVATIONS SHOWN ON THIS PLAN ARE IN METRES AND CAN BE CONVERTED TO FEET BY DIVIDING BY 0.3048.
3. ALL AREAS DISTURBED BY CONSTRUCTION TO BE RESTORED TO ORIGINAL CONDITION.
4. CONTRACTOR TO VERIFY EXACT LOCATION AND DEPTH OF ALL UTILITIES PRIOR TO ANY CONNECTIONS. REPORT ANY DISCREPANCIES TO THE CONSULTANT.
5. CONTRACTOR TO COORDINATE WITH ALL UTILITY COMPANIES FOR INSTALLATION.

+206.45 - INDICATES EXISTING ELEVATION  
 [266.57]+ - INDICATES PROPOSED FINISH ELEVATION

ALL AREAS DISTURBED BY CONSTRUCTION TO BE RESTORED TO ORIGINAL CONDITION

- |  |                                   |                 |                           |
|--|-----------------------------------|-----------------|---------------------------|
| ○ <sup>MH</sup>                                  | MAINTENANCE HOLE                  | ← <sup>HP</sup> | GUY WIRE, UTILITY POLE    |
| ○ <sup>CO</sup>                                  | CLEAN OUT                         | ● <sup>LS</sup> | LIGHT STANDARD            |
| ■ <sup>CB</sup>                                  | CATCH BASIN                       | ● <sup>TL</sup> | TRAFFIC SIGNAL            |
| W <sup>WV</sup>                                  | WATER VALVE                       | ⊥               | FIRE ROUTE SIGN           |
| ○ <sup>CS</sup>                                  | CURB STOP                         | ⊕ <sup>GV</sup> | GAS VALVE                 |
| ○ <sup>HYD</sup>                                 | HYDRANT                           | ♿               | HANDICAPPED PARKING STALL |
| ■ <sup>RIB</sup> ■ <sup>IB</sup> ■ <sup>SR</sup> | SURVEY BARS                       | →               | PROPOSED SWALE            |
| ●  | CONIFEROUS, DECIDUOUS TREE, SHRUB |                 |                           |

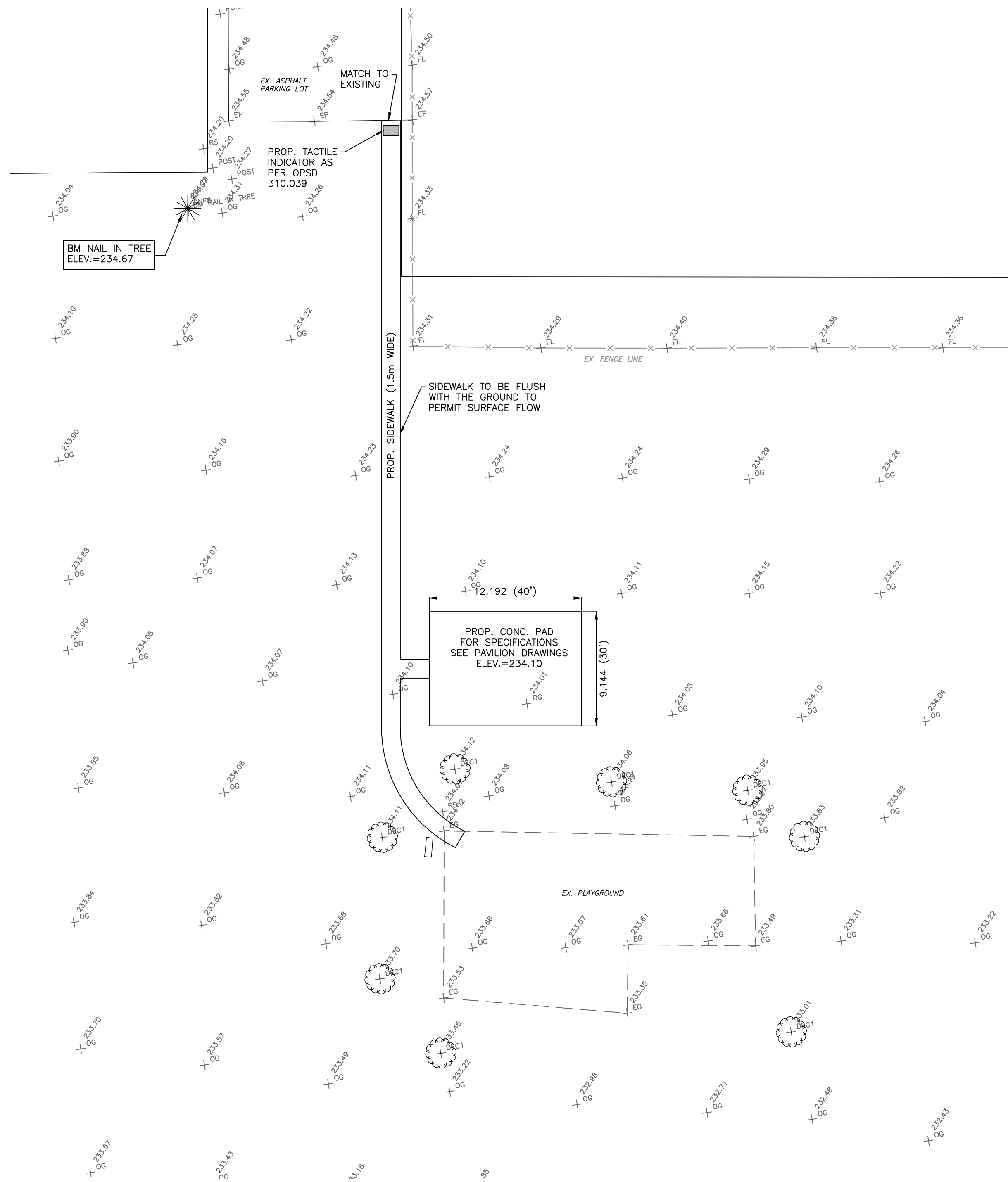

**DETAIL PLAN**  
SCALE: 1 : 250

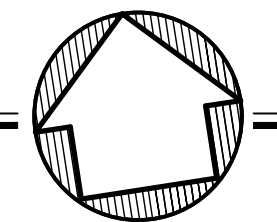

revisions	date	no.
-	-	△

CONTRACTORS MUST CHECK AND VERIFY ALL DIMENSIONS AND REPORT ANY DISCREPANCY TO THIS FIRM BEFORE PROCEEDING WITH THE WORK

- A - detail no.  
 B - location sheet  
 C - detail sheet

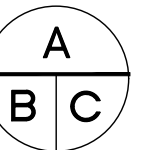

ANYTHING LABELLED 'PROPOSED' ON THIS SET OF DOCUMENTS IS CONSIDERED 'NEW' AND IS TO BE INCLUDED IN THIS CONTRACT



**SPRIET ASSOCIATES**



**LONDON LIMITED architects engineers**

155 York Street - London - N6A 1A8  
 phone : (519) 672-4100 fax : (519) 433-9351  
 e-mail : mail@spriet.on.ca

**EDEN PAVILION AND SIDEWALK**  
 EDEN COMMUNITY PARK  
 MUNICIPALITY OF BAYHAM

drawing title :

SITE PLAN

date : APR. 24, 2026

scale : AS NOTED

drawn by : AH

project no. :

226074

drawing no. :

SP1

# FOUNDATION PLAN

Scale 1/4"=1'-0"

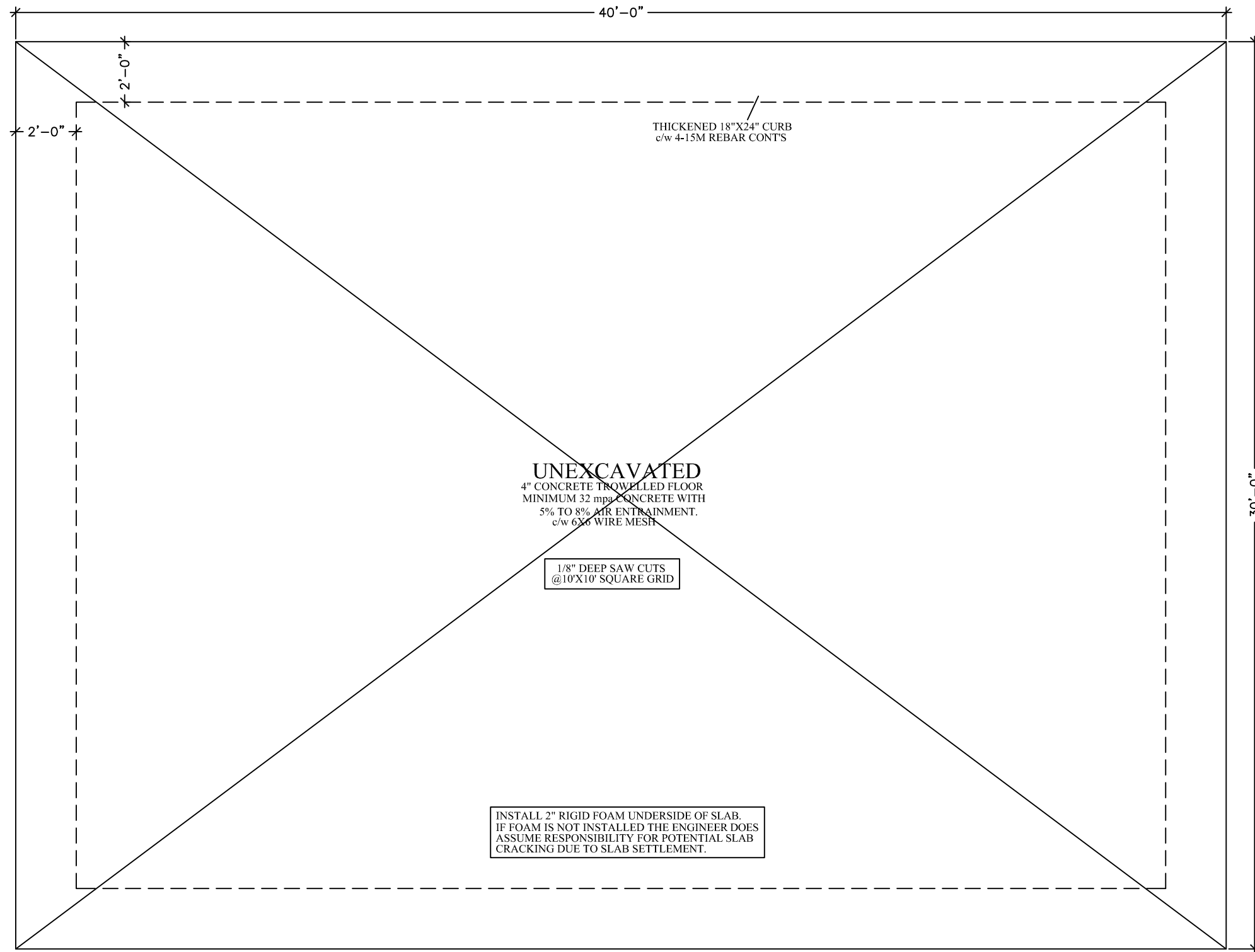

GENERAL NOTES:

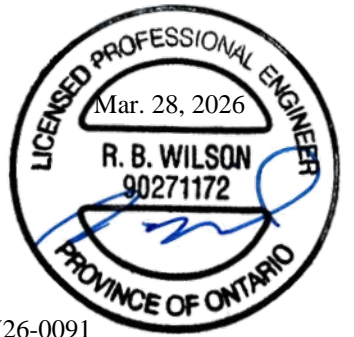

V26-0091  
SEAL COVERS  
STRUCTURAL DESIGN OF  
PAVILION.

SQUARE FOOTAGE	
MAIN FLOOR	1200 SQ.FT.

REV#	DATE	DESCRIPTION
4		
3		
2		
1	03/26	PERMIT ISSUE



\*PROPERTY OF VIEW-IT DESIGN\*

**VIEW-IT DESIGN**  
RR# 1 PORT BURWELL  
OFFICE: 519-851-1173  
FAX: 519-874-4087

EDEN COMMUNITY PARK  
56959 EDEN LINE  
EDEN, ONT

PROPOSED PAVILION PLANS

FOUNDATION PLAN

DRAWN BY: TONY WALL	SCALE: SEE DWG
BCIN: 29620	PO# 2682
DATE: MARCH 2026	<b>A1</b>
SHEET NO. 1 OF 7	

# MAIN FLOOR PLAN

Scale 1/4"-1'-0"

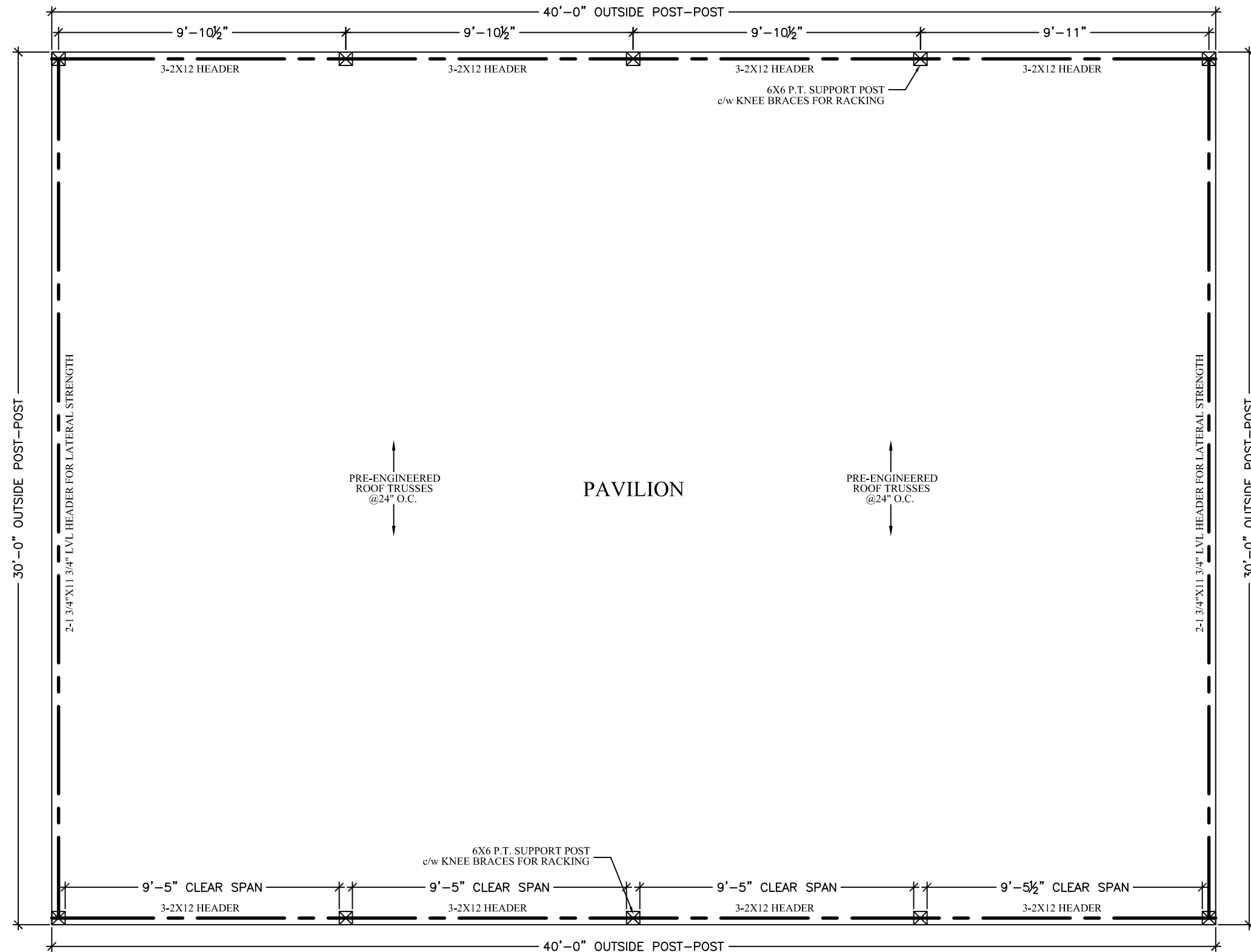

GENERAL NOTES:



V26-0091  
 SEAL COVERS  
 STRUCTURAL DESIGN OF  
 PAVILION.

SQUARE FOOTAGE	
MAIN FLOOR	1200 SQ.FT.

REV#	DATE	DESCRIPTION
4		
3		
2		
1	03/26	PERMIT ISSUE



\*PROPERTY OF VIEW-IT DESIGN\*

**VIEW-IT DESIGN**  
 RR# 1 PORT BURWELL  
 OFFICE: 519-851-1173  
 FAX: 519-874-4087

**EDEN COMMUNITY PARK**  
 56959 EDEN LINE  
 EDEN, ONT

PROPOSED PAVILION PLANS

MAIN FLOOR PLAN

DRAWN BY: TONY WALL      SCALE: SEE DWG

BCIN: 29620      PO# 2682

DATE: MARCH 2026

SHEET NO. 2 OF 7

A2

# ROOF PLAN

Scale 1/4"-1'-0"

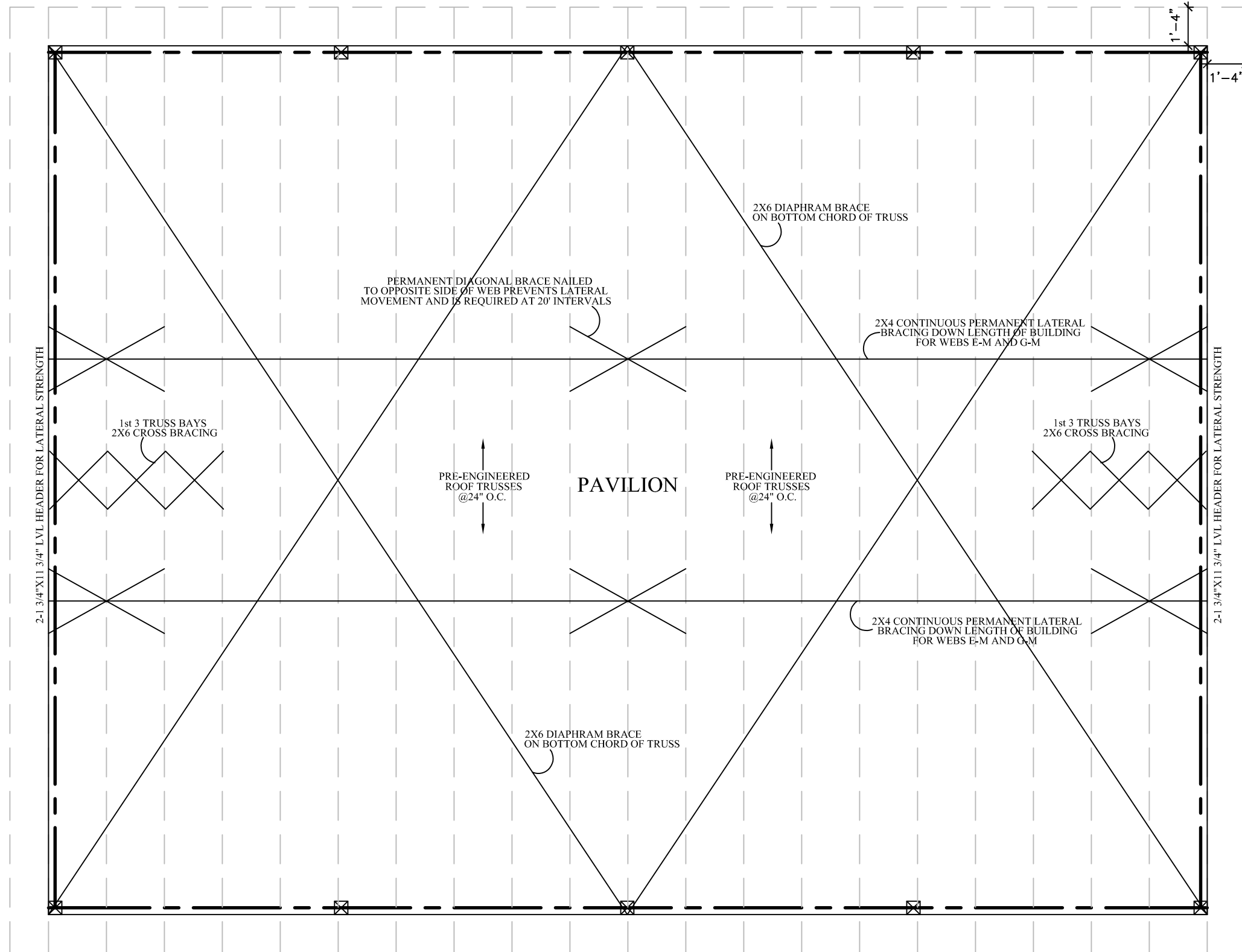

GENERAL NOTES:

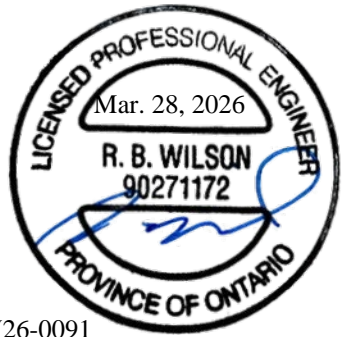

V26-0091  
SEAL COVERS  
STRUCTURAL DESIGN OF  
PAVILION.

SQUARE FOOTAGE	
MAIN FLOOR	1200 SQ.FT.

REV#	DATE	DESCRIPTION
4		
3		
2		
1	03/26	PERMIT ISSUE



\*PROPERTY OF VIEW-IT DESIGN\*

**VIEW-IT DESIGN**  
RR# 1 PORT BURWELL  
OFFICE: 519-851-1173  
FAX: 519-874-4087

**EDEN COMMUNITY PARK**  
56959 EDEN LINE  
EDEN, ONT

PROPOSED PAVILION PLANS

ROOF PLAN

DRAWN BY: TONY WALL	SCALE: SEE DWG
BCIN: 29620 PO# 2682	
DATE: MARCH 2026	
SHEET NO. 3 OF 7	<b>A3</b>

# FRONT ELEVATION

Scale 1/4"-1'-0"

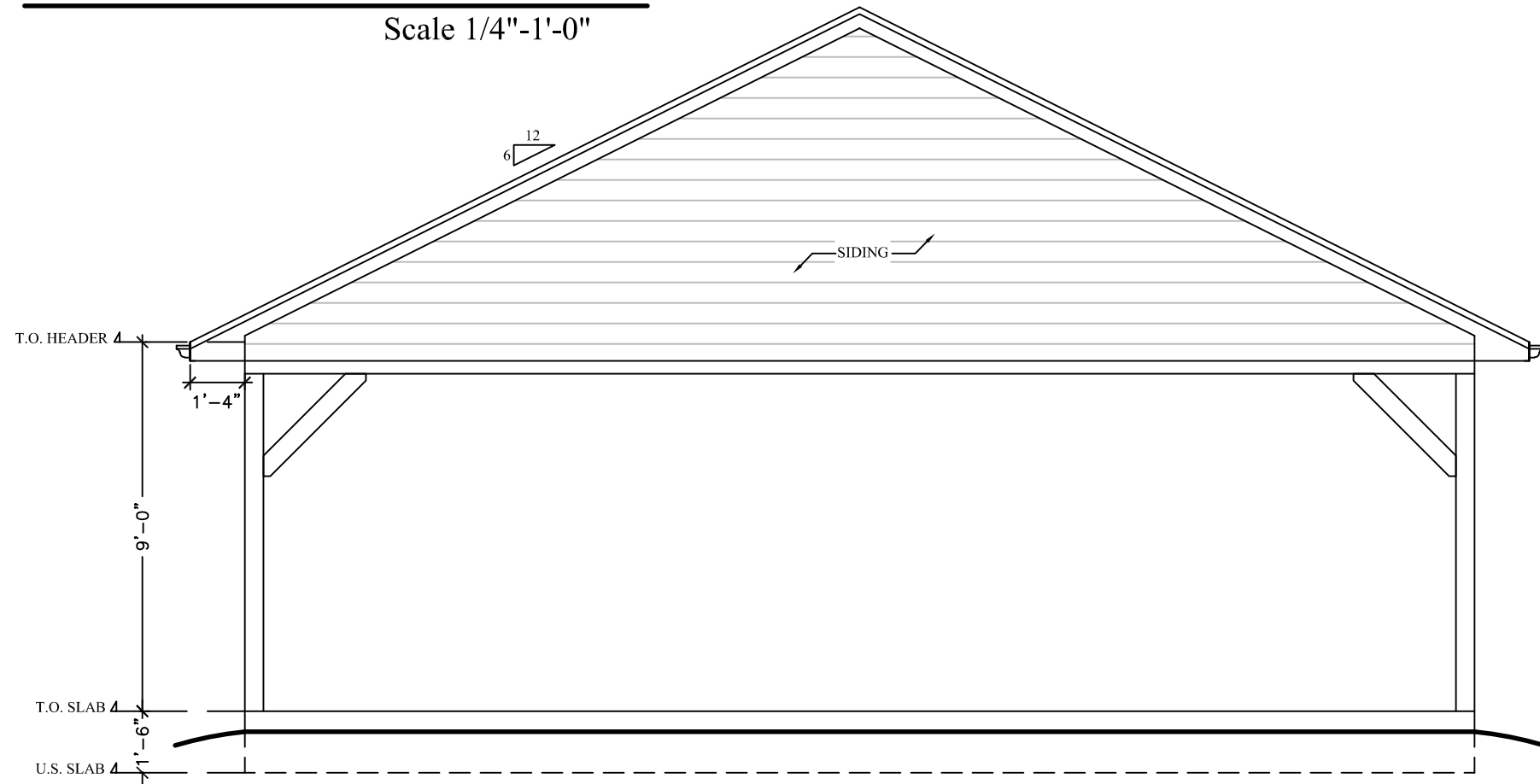

# REAR ELEVATION

Scale 1/4"-1'-0"

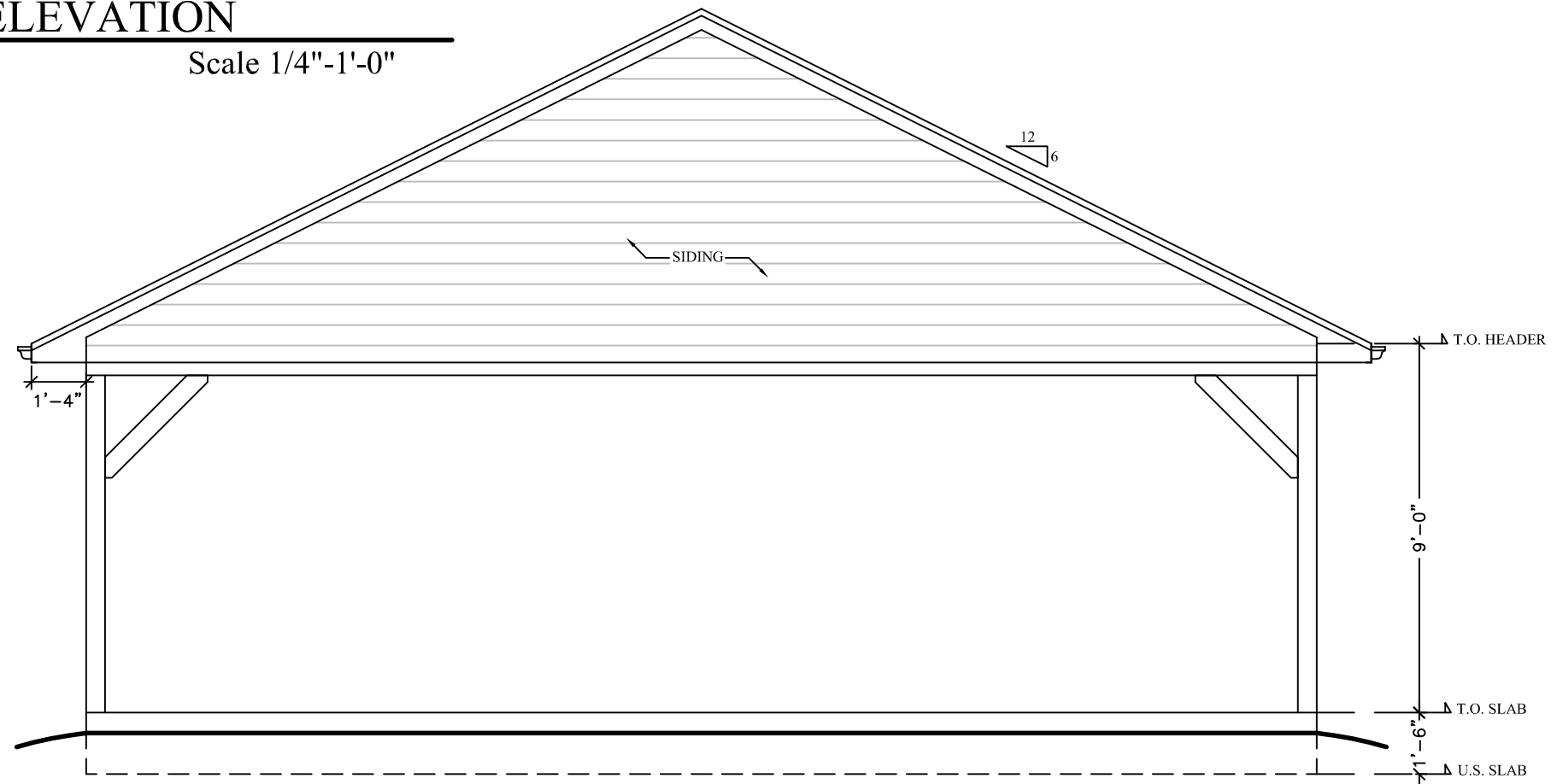

GENERAL NOTES:

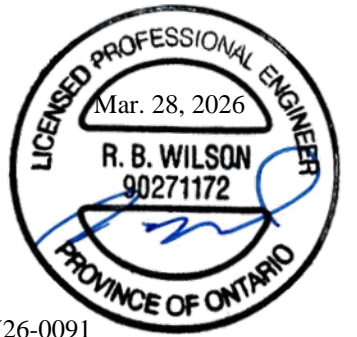

V26-0091  
SEAL COVERS  
STRUCTURAL DESIGN OF  
PAVILION.

SQUARE FOOTAGE	
MAIN FLOOR	1200 SQ.FT.

REV#	DATE	DESCRIPTION
4		
3		
2		
1	03/26	PERMIT ISSUE

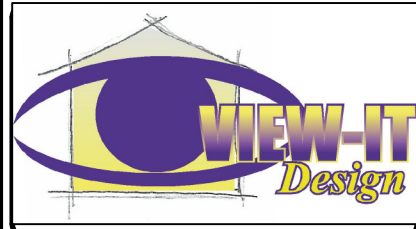

\*PROPERTY OF VIEW-IT DESIGN\*

VIEW-IT DESIGN  
RR# 1 PORT BURWELL  
OFFICE: 519-851-1173  
FAX: 519-874-4087

EDEN COMMUNITY PARK  
56959 EDEN LINE  
EDEN, ONT

PROPOSED PAVILION PLANS

ELEVATIONS

DRAWN BY: TONY WALL	SCALE: SEE DWG
BCIN: 29620 PO# 2682	
DATE: MARCH 2026	
SHEET NO. 4 OF 7	

A4

# RIGHT ELEVATION

Scale 1/4"-1'-0"

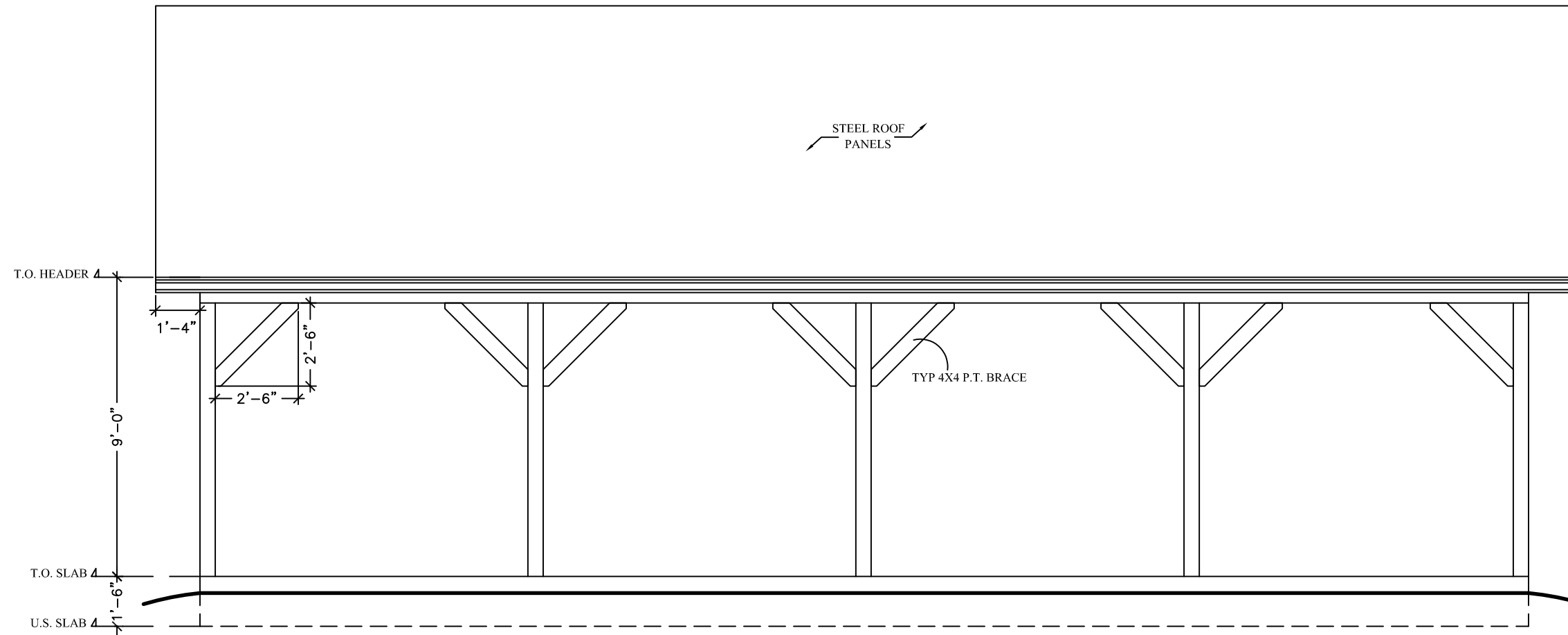

GENERAL NOTES:



V26-0091  
SEAL COVERS  
STRUCTURAL DESIGN OF  
PAVILION.

SQUARE FOOTAGE	
MAIN FLOOR	1200 SQ.FT.

REV#	DATE	DESCRIPTION
4		
3		
2		
1	03/26	PERMIT ISSUE



\*PROPERTY OF VIEW-IT DESIGN\*

**VIEW-IT DESIGN**  
RR# 1 PORT BURWELL  
OFFICE: 519-851-1173  
FAX: 519-874-4087

**EDEN COMMUNITY PARK**  
56959 EDEN LINE  
EDEN, ONT

PROPOSED PAVILION PLANS

ELEVATIONS

DRAWN BY: TONY WALL	SCALE: SEE DWG
BCIN: 29620	PO# 2682
DATE: MARCH 2026	<b>A5</b>
SHEET NO. 5 OF 7	

# LEFT ELEVATION

Scale 1/4"-1'-0"

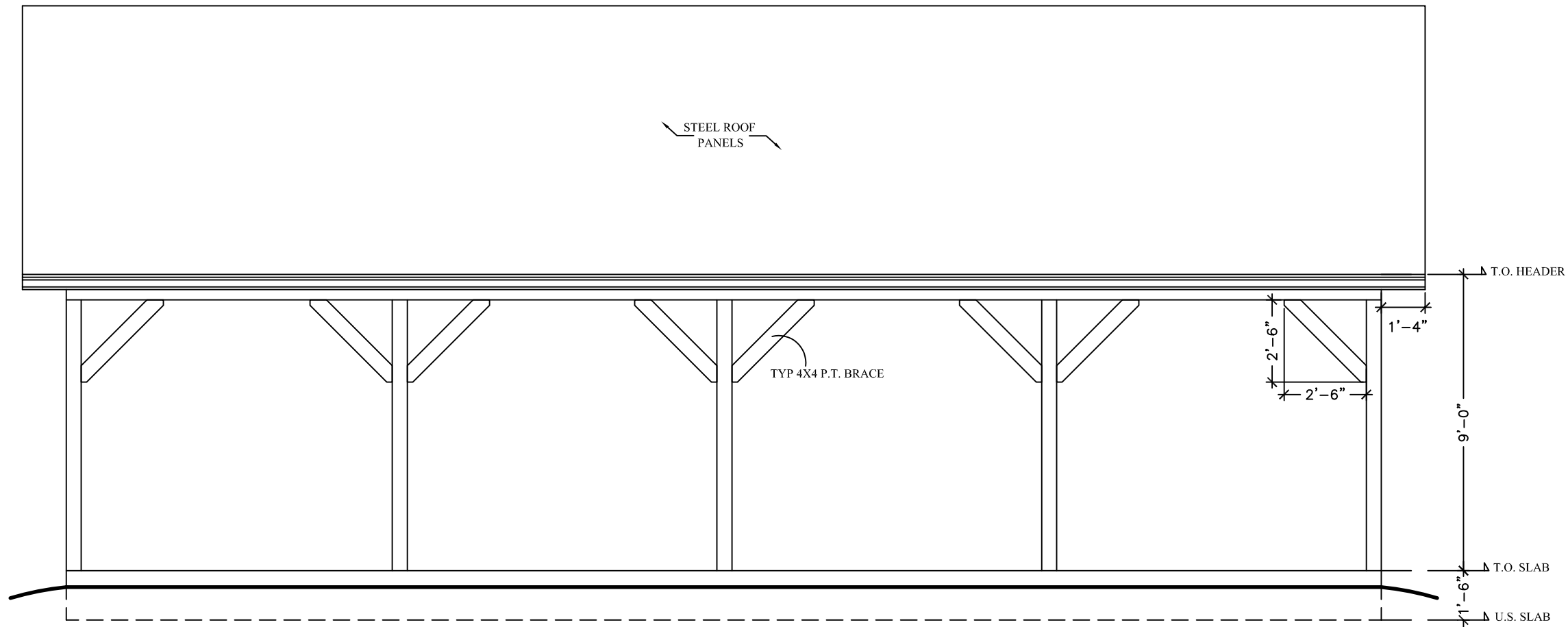

GENERAL NOTES:



V26-0091  
SEAL COVERS  
STRUCTURAL DESIGN OF  
PAVILION.

SQUARE FOOTAGE	
MAIN FLOOR	1200 SQ.FT.

REV#	DATE	DESCRIPTION
4		
3		
2		
1	03/26	PERMIT ISSUE



\*PROPERTY OF VIEW-IT DESIGN\*

**VIEW-IT DESIGN**  
RR# 1 PORT BURWELL  
OFFICE: 519-851-1173  
FAX: 519-874-4087

**EDEN COMMUNITY PARK**  
56959 EDEN LINE  
EDEN, ONT

PROPOSED PAVILION PLANS

ELEVATIONS

DRAWN BY: TONY WALL	SCALE: SEE DWG
BCIN: 29620	PO# 2682
DATE: MARCH 2026	
SHEET NO. 6 OF 7	

**A6**

**GENERAL NOTES:**

CONTRACTOR SHALL REVIEW THE DESIGN DRAWINGS AND REPORT ANY ERRORS OR OMISSIONS TO THE DESIGNER PRIOR TO PROCEEDING WITH THE WORK OF THE CONTRACT. PROCEEDING WITHOUT NOTIFICATION, OR IF CHANGES ARE MADE WITHOUT THE APPROVAL OF THE DESIGNER, WILL VOID ALL RESPONSIBILITY AND LIABILITY OF THE DESIGNER

THE GENERAL CONTRACTOR SHALL PROVIDE MECHANICAL DRAWINGS FOR HEATING & AIR CONDITIONING SYSTEM AND HEAT LOSS & GAIN CALCULATIONS AND BALANCING REPORTS AS MAY BE REQUIRED BY AUTHORITIES HAVING JURISDICTION.

ALL CONSTRUCTION SHALL CONFORM TO THE REQUIREMENTS OF THE ONTARIO BUILDING CODE, AND ALL OTHER APPLICABLE CODES AND REQUIREMENTS OF THE MUNICIPALITY HAVING JURISDICTION.

IT SHALL BE THE RESPONSIBILITY OF THE CONTRACTOR TO CONFORM WITH THESE SECTIONS OF THE CODE WHERE APPLICABLE AND BE FAMILIAR WITH PART 9 OF THE CODE.

**WOOD FRAME CONSTRUCTION**

AS PER OBC SECTION 9.23

ALL STRUCTURAL LUMBER TO BE SPF#2 CONSTRUCTION OR BETTER UNLESS NOTED OTHERWISE. LUMBER SIZES TO BE AS DETERMINED FROM SPAN TABLES OF THE BUILDING CODE.  
 SILL PLATES SHALL BE ANCHORED TO THE FOUNDATION WITH 1/2" ANCHOR BOLTS 7'-10" MAX ON SPACING WITH 4" MIN. EMBEDMENT INTO THE CONCRETE  
 JOIST END BEARING TO BE 1 1/2 MIN.  
 BEAMS & GIRDERS SHALL HAVE 3 1/2" MIN END BEARING  
 BEAMS & POINT LOADS SHALL BE SUPPORTED FULL WIDTH TO FOUNDATION  
 ALL NON LOAD BEARING PARTITIONS SHALL BE SUPPORTED BY DOUBLE FLOOR JOIST OR SOLID BLOCKING AT 3'11" O.C.  
 ALL WOOD IN CONTACT WITH CONCRETE SHALL BE PROTECTED FROM MOISTURE.

**CONCRETE**

AS PER OBC SECTION 9.15 & 9.16

ALL CONCRETE FOOTINGS SHALL BEAR ON UNDISTURBED SOIL WITH A MIN SOIL BEARING PRESSURE OF 2000 PSF  
 CONCRETE FOR FOOTINGS & FOUNDATIONS TO HAVE MIN. COMPRESSIVE STRENGTH OF 20 MPa (2900 PSI) AT 28 DAYS

STEP FOOTINGS:

MAX RISE 600mm (23 5/8") FOR FIRM SOIL  
 MAX RISE 400mm (16" FOR SAND OR GRAVEL  
 MIN RUN BETWEEN RISERS 600mm (23 5/8")  
 ANGLE OF REPOSE IS 45°

CONCRETE FOUNDATION WALLS SHALL EXTEND TO 6" MIN. ABOVE FINISHED GRADE  
 FOOTING DESIGN MIN. 6" DEEP X 4" MIN. PROJECTION BEYOND FOUNDATION WALL AND MIN. OF 16' WIDE  
 CONCRETE FOUNDATIONS SHALL BE CONSTRUCTED TO SUFFICIENT DEPTH TO PROVIDE ADEQUATE FROST PROTECTION

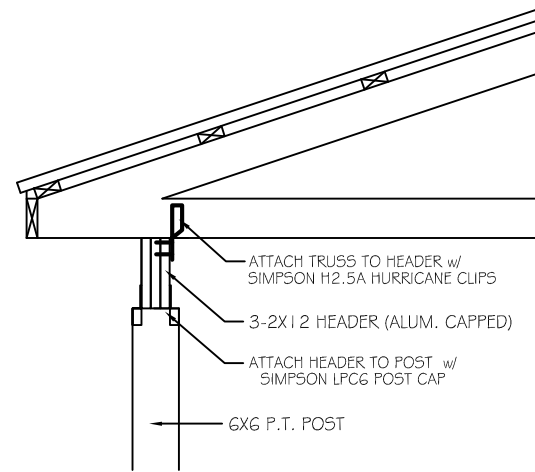

**TRUSS TIE DOWN DETAIL**  
 SCALE: N.T.S. TO STUD WALL

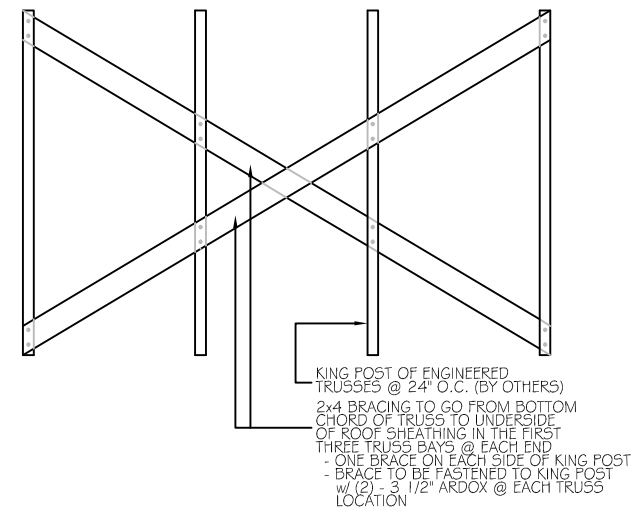

**KING POST BRACING DETAIL**  
 SCALE: N.T.S.

**SECTION 01:01**

Scale 1/4"-1'-0"

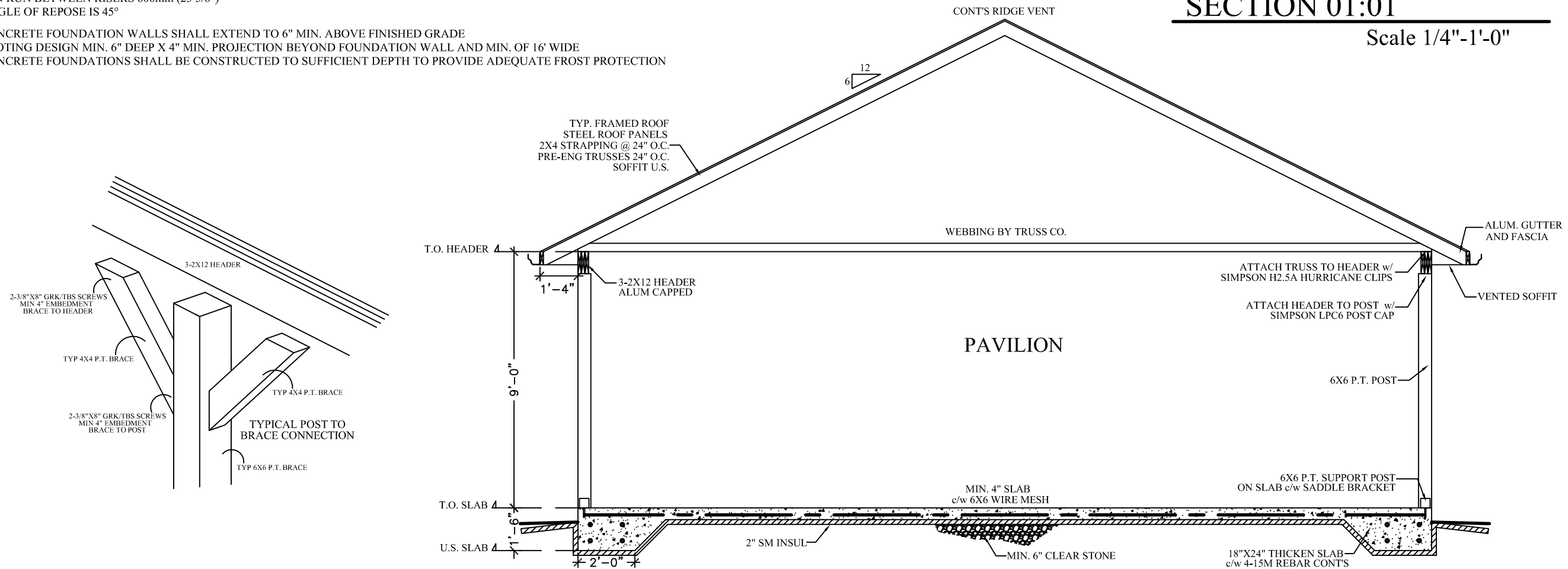

GENERAL NOTES:

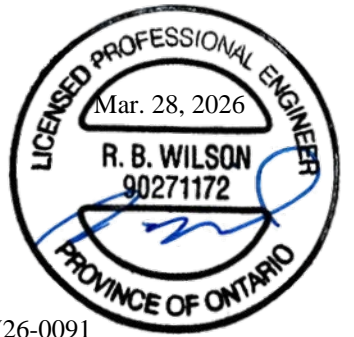

V26-0091  
 SEAL COVERS  
 STRUCTURAL DESIGN OF  
 PAVILION.

SQUARE FOOTAGE	
MAIN FLOOR	1200 SQ.FT.

REV#	DATE	DESCRIPTION
4		
3		
2		
1	03/26	PERMIT ISSUE



\*PROPERTY OF VIEW-IT DESIGN\*

VIEW-IT DESIGN  
 RR# 1 PORT BURWELL  
 OFFICE: 519-851-1173  
 FAX: 519-874-4087

EDEN COMMUNITY PARK  
 56959 EDEN LINE  
 EDEN, ONT

PROPOSED PAVILION PLANS

SECTION/ DETAILS

DRAWN BY: TONY WALL	SCALE: SEE DWG
BCIN: 29620	PO# 2682
DATE: MARCH 2026	
SHEET NO. 7 OF 7	

**A7**



COMPANY

PROJECT

Mar. 28, 2026 11:01

V26-0090 eden community park side beams

**Design Check Calculation Sheet**

WoodWorks Sizer 12.1

**Loads:**

Load	Type	Distribution	Pat-tern	Location [ft]		Magnitude		Unit
				Start	End	Start	End	
Load1	Snow	Full UDL				583.0		plf
Load2	Live ext	Full UDL				150.0		plf
Load3	Dead	Full UDL				186.5		plf
Load4	Wind	Full UDL				39.5		plf
Self-weight	Dead	Full UDL				9.2		plf

Load magnitude does not include Normal Importance factor from NBC Tables 4.1.6.2, 4.1.7.3, 4.1.8.2 which is applied during analysis.

**Reactions (lbs), Bearing Resistances (lbs) and Bearing Lengths (in) :**

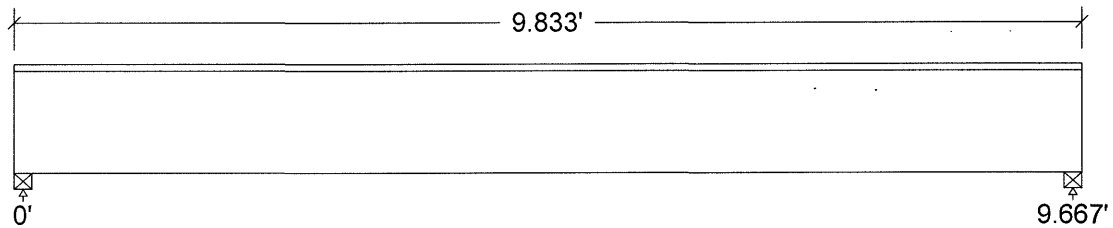

Unfactored:			
Dead	961		961
Live	738		738
Snow	2866		2866
Wind	194		194
Factored:			
Maximum	5579		5579
Critical	5501		5501
Bearing:			
Capacity			
Beam	5501	<p>CONNECT TOGETHER USING 3 ROWS OF 3" COMMON WIRE (10D) NAILS STAGGERED AT 12" O/C SPACING</p> <p><i>as each layer is applied</i></p> <p>MAR 28 2026</p> 	5501
Support	7873		7873
Des ratio			
Beam	1.00		1.00
Support	0.70		0.70
Load comb	#3		#3
Length	1.99		1.99
Min req'd	1.99		1.99
KB	1.00		1.00
KB min	1.00		1.00
KD	1.00	1.00	
KB support	1.08	1.08	
fcp sup	1015	1015	
Kzcp sup	1.00	1.00	

**Built-up, S-P-F, No.1/No.2, 2x12, 3-ply (4-1/2"x11-1/4")**

Supports: All - Timber Beam, D.Fir-L No.2

Total length: 9.83'; Clear span: 9.667'; Volume = 3.5 cu.ft.

Load sharing: Yes; Lateral support: top = continuous, bottom = at supports;

**This section PASSES the design code check.**

*V26-0090  
E9082*

**Force vs. Resistance and Deflection using CSA O86-19:**

Criterion	Analysis Value	Design Value	Unit	Analysis/Design
Shear	Vf @d = 4266	Vr = 7256	lbs	Vf/Vr = 0.59
Moment (+)	Mf = 13073	Mr = 13391	lbs-ft	Mf/Mr = 0.98
Perm. Defl'n	0.05 = < L/999	0.32 = L/360	in	0.16
Live Defl'n	0.14 = L/813	0.48 = L/240	in	0.29
Total Defl'n	0.19 = L/595	0.64 = L/180	in	0.30

**Additional Data:**

FACTORS:	f/E(psi)	KD	KH	KZ	KL	KT	KS	KN	LC#
Fv	218	1.00	1.10	1.000	-	1.00	1.00	-	#3
Fb+	1711	1.00	1.10	1.000	1.000	1.00	1.00	-	#3
Fcp	769	-	-	1.000	-	1.00	1.00	-	#-
Es	1.4 million	-	-	-	1.000	1.00	1.00	-	#6

**CRITICAL LOAD COMBINATIONS:**

Shear : LC #3 = 1.25D + (1.0)1.5S  
 Moment (+) : LC #3 = 1.25D + (1.0)1.5S  
 Deflection: LC #1 = 1.0D (permanent)  
 LC #6 = 1.0D + (0.9)1.0S + (0.75)0.3W (live)  
 LC #6 = 1.0D + (0.9)1.0S + (0.75)0.3W (total)  
 Bearing : Support 1 - LC #6 = 1.25D + (1.0)1.5S + (1.0)0.4W  
 Support 2 - LC #6 = 1.25D + (1.0)1.5S + (1.0)0.4W

Load Types: D=dead W=wind S=snow  
 L=live(use, occupancy)

Load Patterns: s=S/2 L=L+Ls \_=no pattern load in this span

Load combinations from NBC 2020; code references and LC's listed  
 in the Analysis report

**CALCULATIONS:**

EI = 245.23e06 lb-in<sup>2</sup>/ply

"Live" deflection is due to all non-dead loads (live, wind, snow...)

**Design Notes:**

1. WoodWorks analysis and design are in accordance with the 2020 National Building Code of Canada (NBC), Division B, Part 4, and the CSA O86-19 Engineering Design in Wood standard.
2. Please verify that the default deflection limits are appropriate for your application.
3. KL calculated as per O86 7.5.6.4
4. BEAMS require restraint against lateral displacement and rotation at points of bearing (O86 6.5.3.2.3).
5. BUILT-UP BEAMS: it is assumed that each ply is a single continuous member (that is, no butt joints are present) and that each ply is equally top-loaded. Where beams are side-loaded, special fastening details may be required.

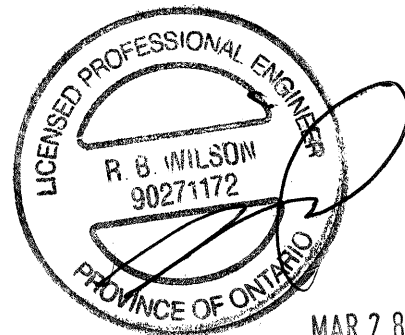

# COMMITMENT TO GENERAL REVIEWS BY ARCHITECT AND ENGINEERS

THIS FORM TO BE COMPLETED BY THE OWNER OR OWNER'S AUTHORIZED AGENT, AND SIGNED BY ALL CONSULTANTS RETAINED FOR GENERAL REVIEWS

## Part A - Owner's Undertaking

Permit Application No.

Project Description:

Proposed Pavilion / Eden Community Park

Address of Project:

56959 Eden Line, Eden, ONTARIO

Municipality:

BAYHAM/MALAHIDE TWP.

WHEREAS the Ontario Building Code requires that the project described above be designed and reviewed during construction by an architect, professional engineer or both that are licensed to practice in Ontario;

NOW THEREFORE the Owner, being the person who intends to construct or have the building constructed hereby warrants that:

1. The undersigned architect and/or professional engineers have been retained to provide general reviews of the construction of the building to determine whether the construction is in general conformity with the plans and other documents that form the basis for the issuance of a building permit, in accordance with the performance standards of the Ontario Association of Architects (OAA) and/or Professional Engineers Ontario (PEO);
2. All general review reports by the architect and/or professional engineers will be forwarded promptly to the Chief Building Official, and
3. Should any retained architect or professional engineer cease to provide general reviews for any reason during construction, the Chief Building Official will be notified in writing immediately, and another architect or engineer will be appointed so that general review continues without interruption during construction.

The undersigned hereby certifies that he/she has read and agrees to the above

Name of Owner:

Date:

Address of Owner:

Telephone:

Signature of Owner:

Print Name:

Fax:

(or officer of corporation)

Coordinator of the work of all consultants:

Telephone:

Address:

Fax:

## Part B - Consultants

The undersigned architect and/or professional engineer(s) hereby certify that they have been retained to provide general reviews of the parts of construction of the building indicated, to determine whether the construction is in general conformity with the plans and other documents that form the basis for the issuance of a building permit, in accordance with the performance standards of the OAA and/or PEO.

SHADED PORTION TO BE COMPLETED BY CONSULTANTS

ARCHITECTURAL    STRUCTURAL    MECHANICAL    ELECTRICAL    SITE SERVICES    OTHER (SPECIFY):

Consultant Name: B. WILSON ENGINEERING INC.   Signature: [Signature]   Print Name: BRAD WILSON   Date: MARCH 28/26

Telephone: (519) 264-1154   Fax: —   Address: 9037 GLENDON DRIVE, MT. BRADGES, ONT. N0L1W0

ARCHITECTURAL    STRUCTURAL    MECHANICAL    ELECTRICAL    SITE SERVICES    OTHER (SPECIFY):

Consultant Name:   Signature:   Print Name:   Date:

Telephone:   Fax:   Address:

ARCHITECTURAL    STRUCTURAL    MECHANICAL    ELECTRICAL    SITE SERVICES    OTHER (SPECIFY):

Consultant Name:   Signature:   Print Name:   Date:

Telephone:   Fax:   Address:

ARCHITECTURAL    STRUCTURAL    MECHANICAL    ELECTRICAL    SITE SERVICES    OTHER (SPECIFY):

Consultant Name:   Signature:   Print Name:   Date:

Telephone:   Fax:   Address:

